

Installation Guide for EM1 & ESM

Description:

The EM1 is designed to operate and monitor emergency stop buttons and/or any two normally open safety device.

The master control unit (EM1) can monitor individual E'stop devices via an ESM module up to 30 inputs. The master control unit is supplied with 24VDC as standard and features an internal resettable fuse.

This product is perfect for anyone looking for a fully modular system that **does not require programming**. The EM1 is approved by TUV to CAT 4 SIL3 PLe and cUL listed.



KEEP THIS GUIDE FOR FUTURE REFERENCE

The information is designed to help suitably qualified personnel install and operate Mechan Controls safety equipment. Before using this product, read this guide thoroughly along with any relevant European and/or National Standards E.g. Machinery Directive 2006/42/EC and its Amendments, Provision and Use of Work Equipment Regulations. **Further information can be obtained from Mechan Controls Ltd.**

Technical Specifications	EM1	ESM
Supply Nominal Voltage	24Vdc	-
Nominal Power Consumption	6VA	3VA
Safety Contacts	2 x N/O	-
Auxiliary Contact	1 x N/C	-
Output Contact Rating (Max)	4A/230Vac; 2A/24Vdc(Res.)@Cos=1	-
Output Contact Rating (Min)	10V/10mA	-
Output Contact Fuse Rating	AC=5A; DC=2.5A; Quick blow	-
Max Conductor Size	2 x 1.5mm Stranded with Sleeves, 2 x 2.5mm Solid	2 x 1.5mm Stranded with Sleeves, 2 x 2.5mm Solid
Internal Fuse / Recovery Time	1.6 Amp Resettable / >2 Seconds	500mA Resettable / >2 Seconds
Indication	LED Status Indication	LED Status Indication
Enclosure Protection	Housing IP30, Terminals IP20	-
Operating Temperature	0C to +45C (85% Humidity Max)	0C to +45C (85% Humidity Max)
Storage Temperature	-20C to +60C	-20C to +60C
Mounting / Fixing	35mm Symmetric DIN Rail	35mm Symmetric DIN Rail

Safety Related Data

B10d	2,000,000	PFH	6.52 x 10 ⁻⁹
TM (Mission Time)	20 Years	PFHd	6.0 x 10 ⁻⁹
DC	99%	SFF	99.50%
MTTFd	High > 100 Years (based on usage rate of 360 days/year, 24 hours/day, 10 Operations/hour)		
PL in accordance with EN ISO 13849-1	PL-e, CAT 4		
SIL CL in accordance with EN IEC 62061	SIL3		

Safety Standards

Approvals	CE Complies with all relevant sections of the CE Marking Directive
	TUV Approved to CAT 4 SIL 3 PLe / cUL Approved
International Directives	Machinery Directive 2006/42/EC, Low Voltage Directive 2014/35/EU; EMC Directive 2014/30/EU, RoHS Directive 2011/65/EC
International Standards	BS EN 12100 Safety of Machinery. General principles for design.
	BS EN ISO 14119 Safety of Machinery. Interlocking devices associated with guards.
	BS EN ISO 13849 Safety of Machinery. Safety related parts of control systems.
	BS EN ISO 62061 Safety of Machinery. Functional safety of safety related electrical, electronic and programmable electronic control systems
	BS EN 60204 Safety of Machinery. Electrical equipment of machines.
	BS EN 60947-5-1 Low-voltage switchgear and controlgear.
	BS EN 60947-5-3 Low-voltage switchgear and controlgear.

Dimensions

EM1

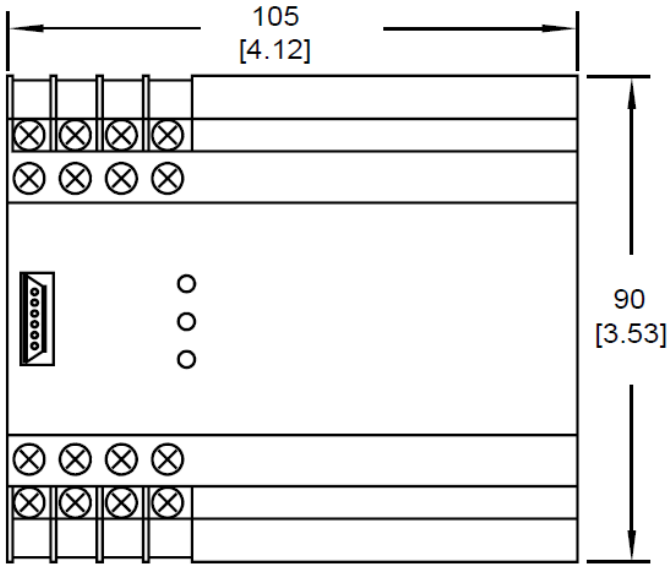

ESM

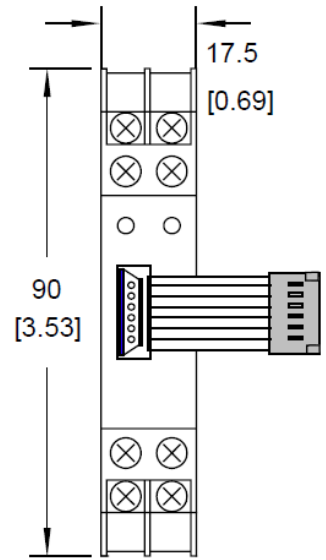

System Assembly

Assemble the required number of modules on the DIN-Rail, starting with the EM1 and clipping the ESM's to the left of the EM1.

The ESM requires 2 x N/O inputs from an Emergency stop button, or other mechanical safety rated switch.

The maximum number of inputs that can be monitored by a DC supplied EM1 safety system is 30.

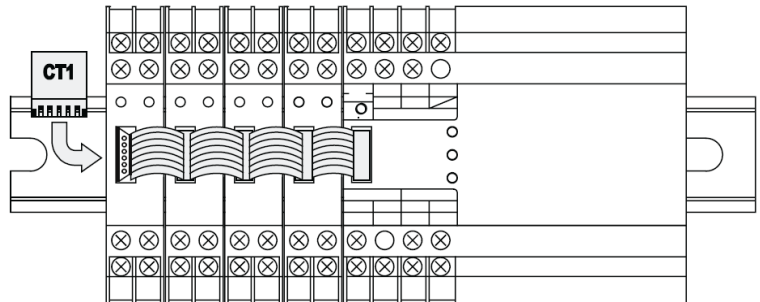

The 'Control Bus' straps on each extender unit connect to the adjacent (right hand side) module as shown.

The 'Control Bus' terminator, CT1 (supplied with the EM1), must be plugged into the last extender module in the system.

Mounting on 35mm DIN Rail

The control modules are designed to be mounted in an IP55 (minimum) control cabinet. The modules clip on too standard 35 mm symmetric (top hat) DIN-Rail

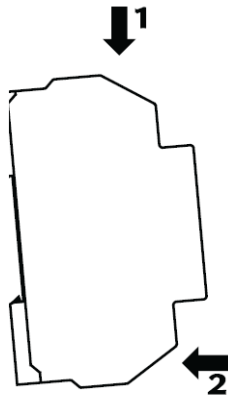

Removal from 35mm DIN Rail

To remove the modules, gently lever out the DIN clip with a small screwdriver as shown (1). Tilt the unit in the direction (2) and slip the unit off the DIN Rail (3)

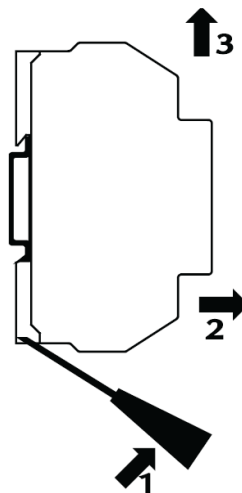

EM1 / ESM Connections

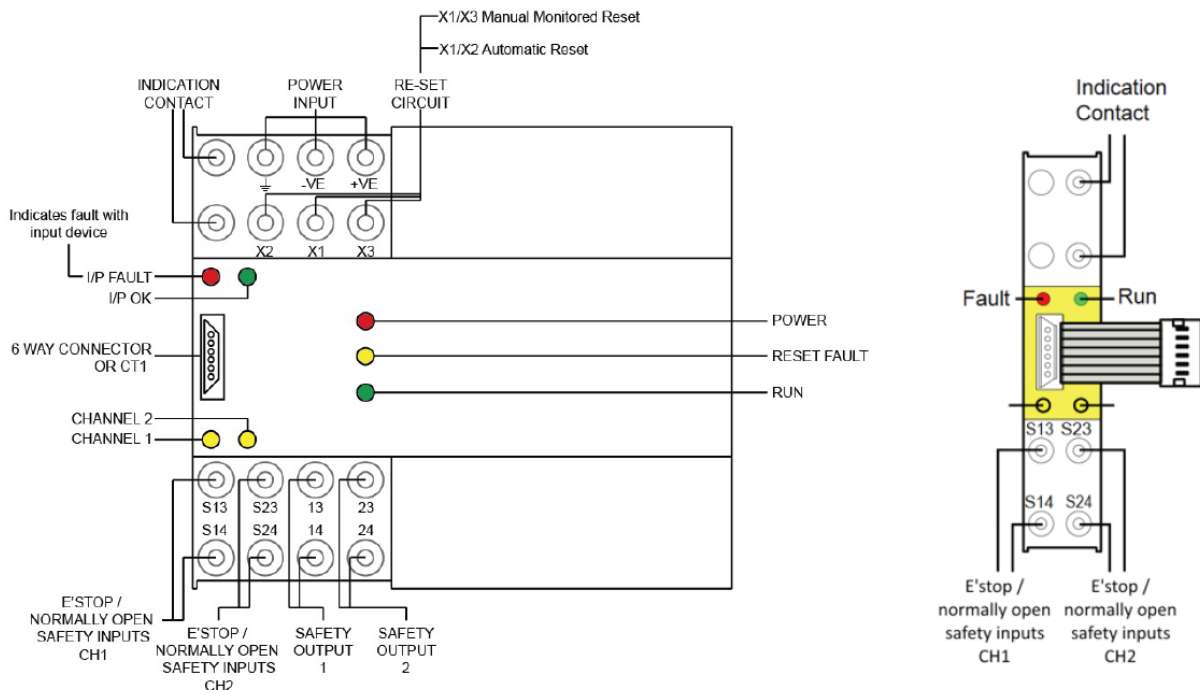

Important

Maintenance

It is recommended to check the safe operation of the modules and look for signs of damage or excessive wear on a weekly basis. Damaged units should be replaced or returned to the manufacturer for repair where practical.

Declaration of Conformity

Mechan Controls declares that the products shown conform to the Essential Health and Safety Requirements of the European Machinery Directive. The above products have been third party tested to conform to the requirements of EN-13849-1 and EN 62061. Full declaration of conformity can be downloaded from the Mechan Controls web site www.mechancontrols.com or by contacting Mechan directly Tel: + 44 1695 722264

Notes

In the interest of product development specifications are subject to change without notice. It is the responsibility of the user to ensure compliance with any acts or by-laws in place. All information regarding Mechan equipment is believed to be accurate at the time of printing. Responsibility cannot be accepted for errors or omissions.



MECHAN CONTROLS LTD
14/16 Seddon Place, Stanley Industrial Estate
Skelmersdale
WN8 8EB

Telephone: +44 (0) 1695 722 264
Email: sales@mechancontrols.co.uk
Web: www.mechancontrols.com